

1st Operation : Station 2 - Punch the relevant Ø5.00 holes
2st Operation No.2 : Station 4 - Enter the profile and locate the stop-pin inside hole "A"

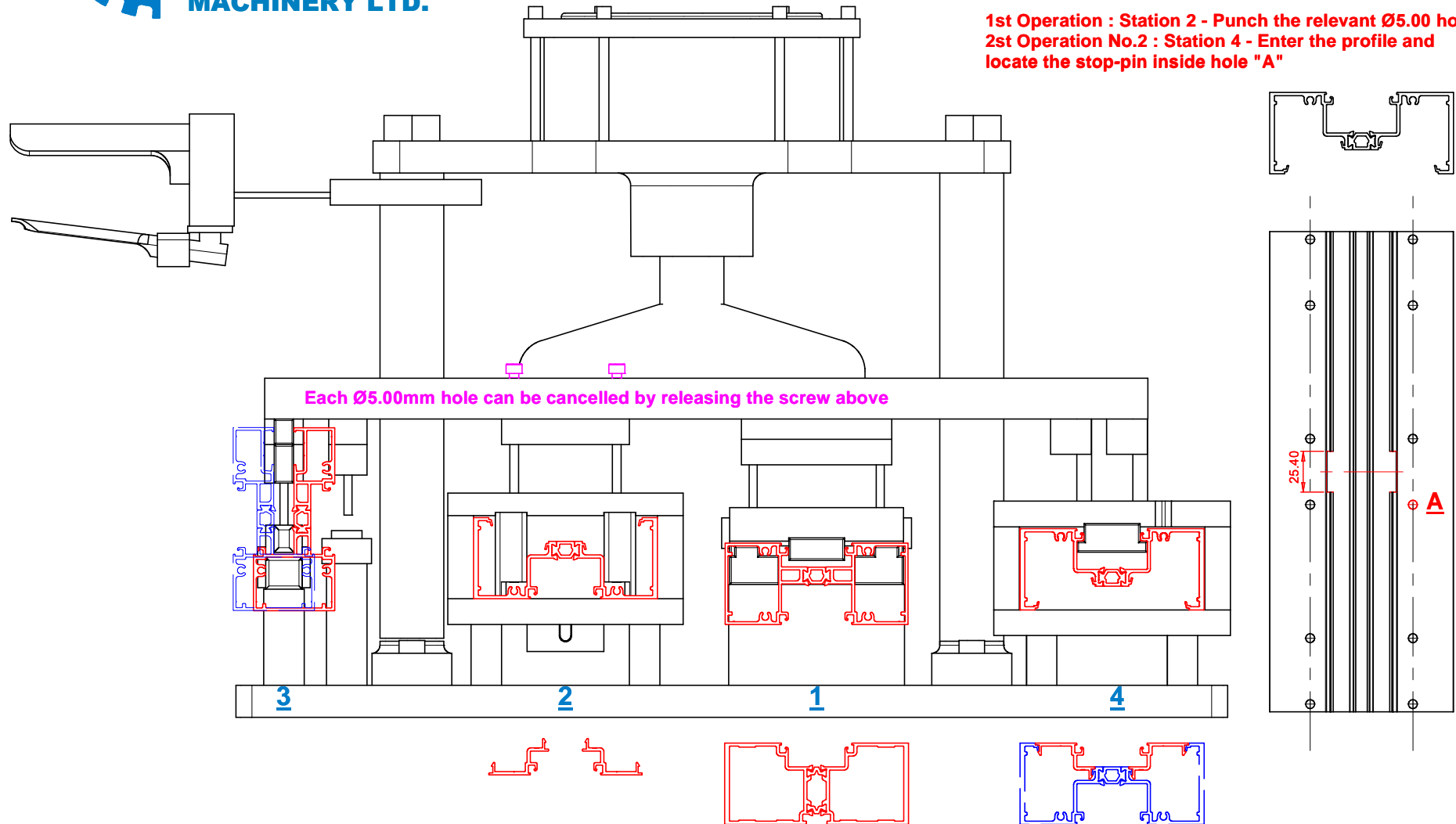

**Punch only after assembling profiles
 No.450040 and No.450030 as shown**

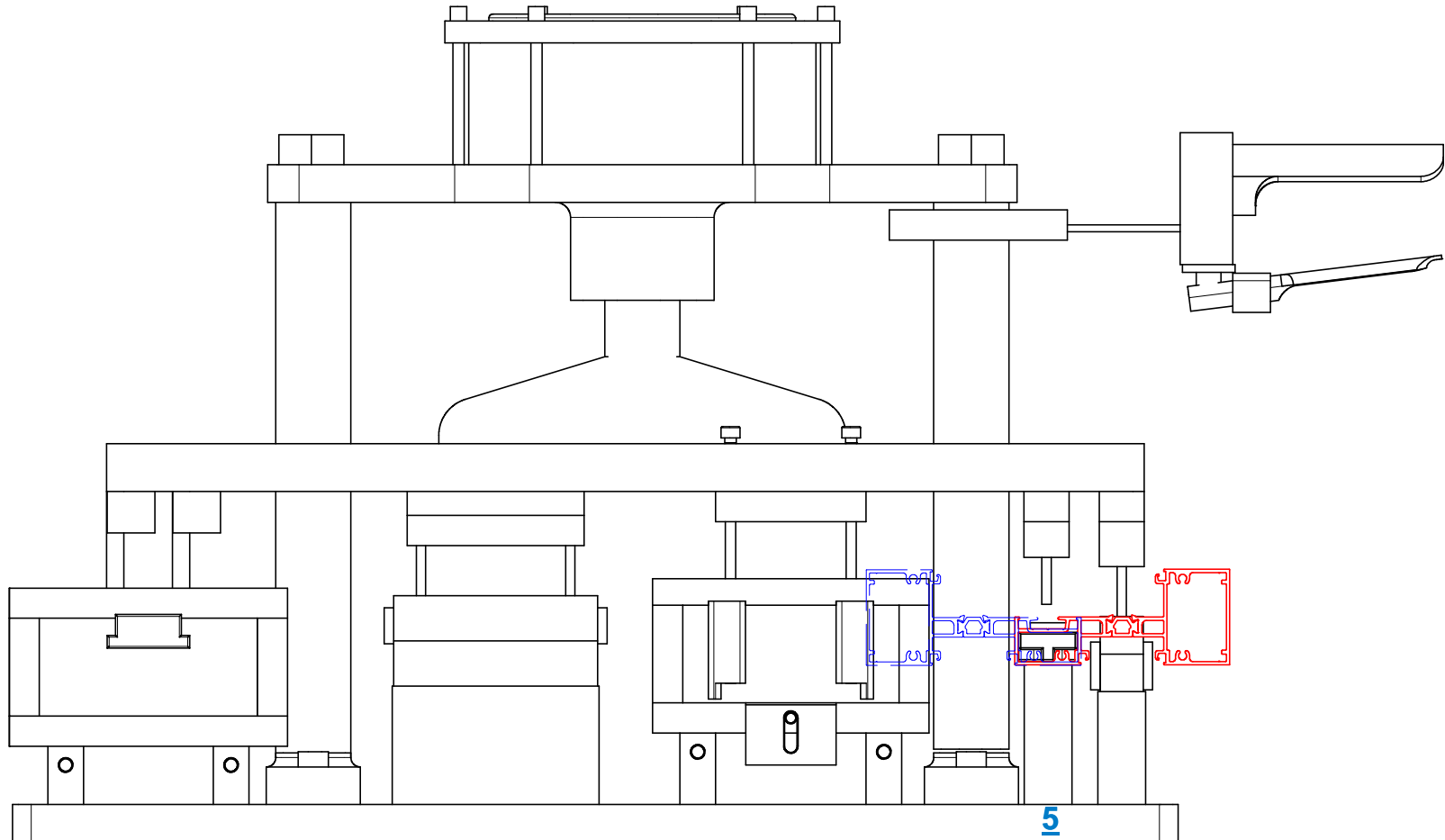



SHOHAM
MACHINERY LTD.

Model MERIDIAN 450

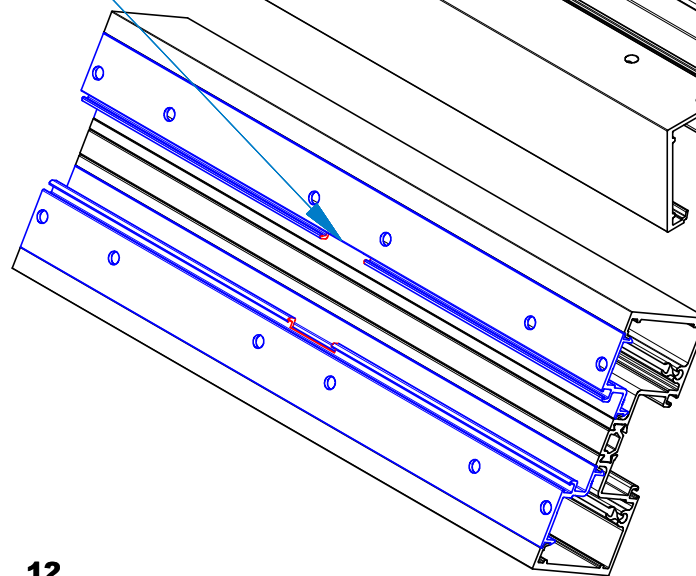
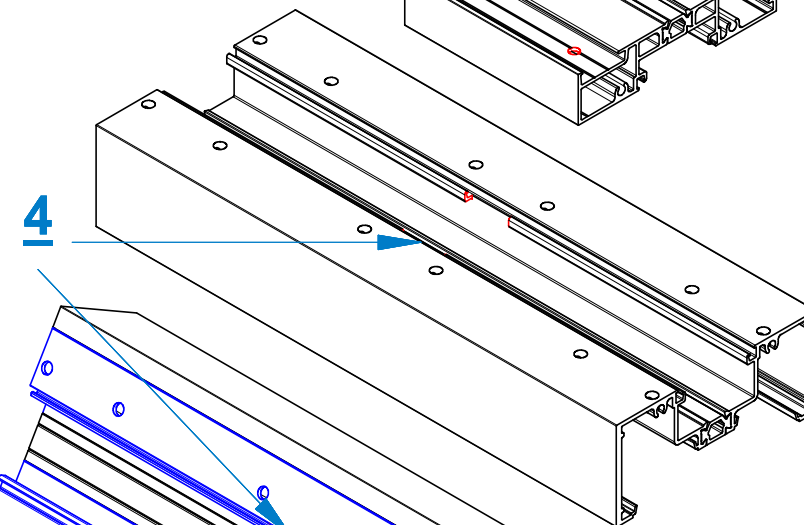
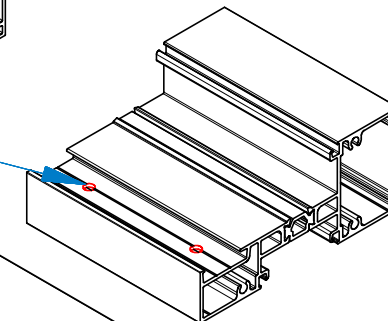
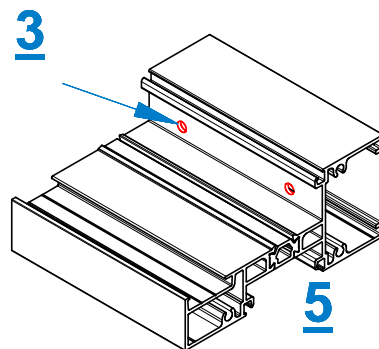
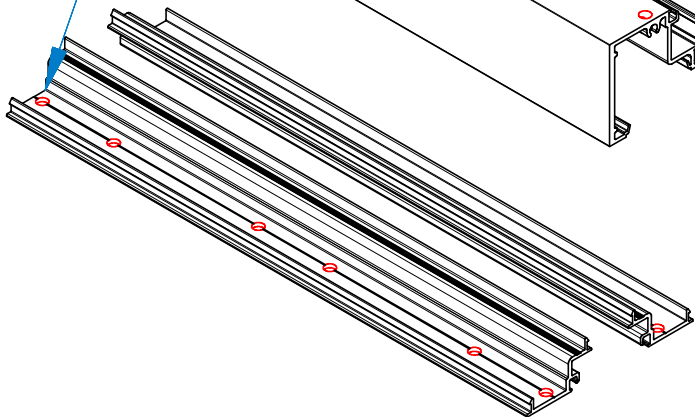
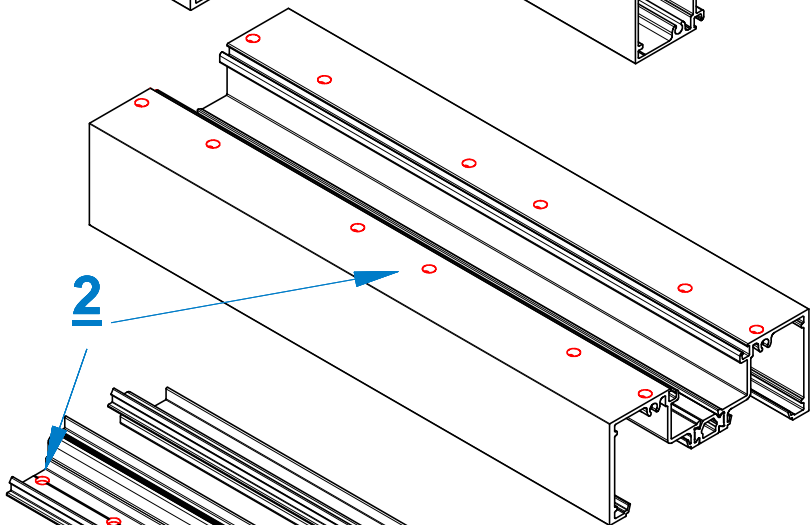
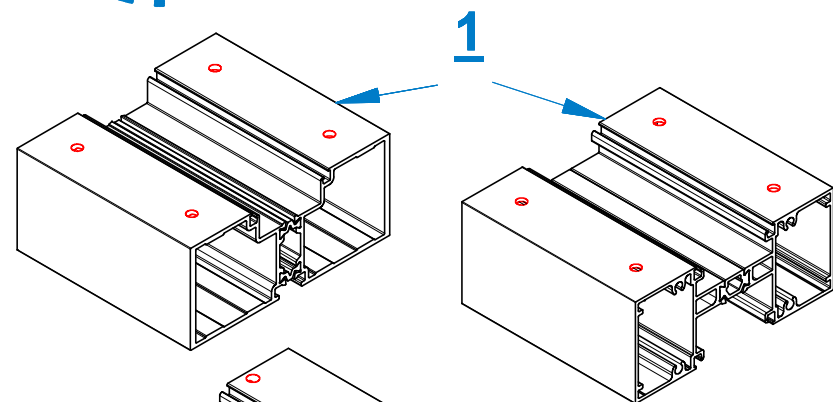

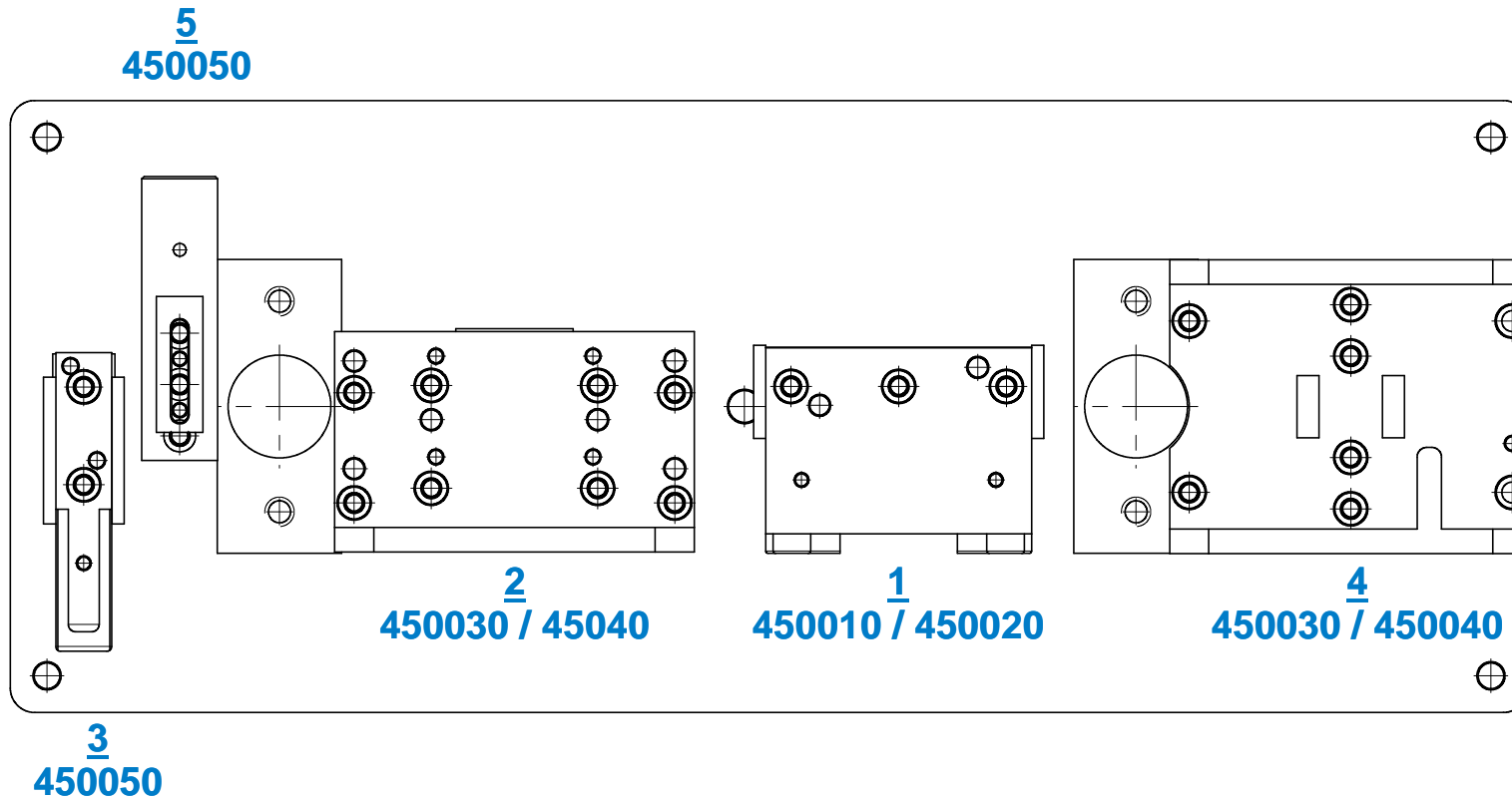

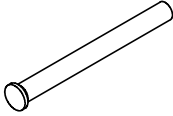
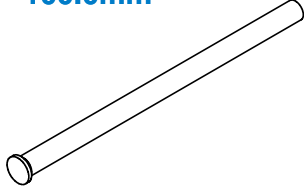
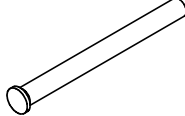
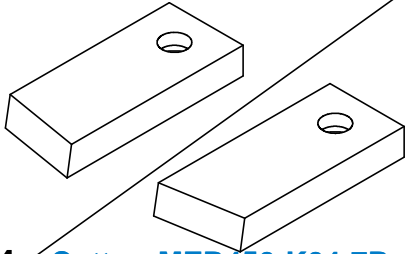
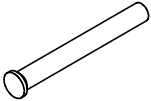
<p>Cutter: MER450-K01-7 (Ø5.0mm) 1 unit - 46.0mm 1 unit - 50.0mm</p>  <p style="text-align: right;">STATION No.1</p> <p>1</p>	<p>Cutter: MER450-K02-8 (Ø5.5mm) 2 unit - 94.0mm 2 unit - 100.0mm</p>  <p style="text-align: right;">STATION No.2</p> <p>2</p>	<p>Cutter: MER450-K03-7 (Ø5.0mm) 1 unit - 54.0mm</p>  <p style="text-align: right;">STATION No.3</p> <p>3</p>	<p>Cutter: MER450-K04-7L</p>  <p style="text-align: right;">STATION No.4</p> <p>4 Cutter: MER450-K04-7R</p>
<p>Cutter: MER450-K05-5 (Ø5.0mm) 1 unit - 42.0mm</p>  <p style="text-align: right;">STATION No.5</p> <p>5</p>			